

# Optical Thunderbolt Cable

Yasuhiro MAEDA\*, Michiko HARUMOTO, Takayuki SHIMAZU, Yuya HOMMA, Mitsuaki TAMURA and Yoshiki CHIGUSA

Thunderbolt, an innovative high-speed input/output (I/O) technology developed by Intel Corporation and Apple Inc., enables 10Gb/s transmission between a computer and peripheral devices. Based on Intel's technical specifications, Sumitomo Electric Industries, Ltd. has developed an Optical Thunderbolt Cable by drawing on its optical fiber and module technologies. The Optical Thunderbolt Cable has the capability of long-distance transmission of up to 30 meters, excellent robustness, durability, and flexibility when using specially designed optical fiber. This paper describes the outline of Optical Thunderbolt Cable design and test results of its characteristics and reliability.

Keywords: Thunderbolt, optical cable

## 1. Introduction

In recent years, data communication traffic that information terminals (personal computers, tablet computers, and smart phones) handle has been rapidly increasing as picture and screen image resolution is getting higher. Therefore, further high-speed interfaces that connect these devices are required. In addition, the consolidation of interfaces, for which many standards exist today, is expected because physical space to accommodate interface connectors is restricted as these devices become thinner and smaller. Thunderbolt has been proposed to solve these problems.

Thunderbolt is a high-speed data transmission standard jointly developed by Intel Corporation and Apple Inc. Thunderbolt provides two lanes of 10 Gb/s bidirectional transmission channels and supports dual protocols of PCI Express\*<sup>1</sup> for data transfer technology and DisplayPort\*<sup>2</sup> for video output. Thunderbolt also has high extensibility since it can support daisy chain\*<sup>3</sup> connection and handle many interfaces by connecting to the docking station\*<sup>4</sup>. **Table 1** shows a comparison between Thunderbolt and USB, which is the generally used interface to connect consumer devices.

Thunderbolt has gradually become popular mainly in Apple products since it was created in 2011. It appears that this technology will continue to grow along with the in-

crease of consumer devices, including Windows machines that support Thunderbolt interface. We have already developed an Electrical Thunderbolt Cable by drawing on our electric cable and high-speed transmission technologies based on Intel's technical specifications and it has won a favorable reputation. On the other hand, the development of a cable that supports longer distance (more than 3 m) has been anticipated by media creators and editors. In response to this demand, we have developed an Optical Thunderbolt Cable that supports long-distance transmission of up to 30 meters by drawing on our optical fiber and module technologies. We received the world's first Optical Thunderbolt Cable certification and started mass production in January 2013.

This paper describes the outline of the Optical Thunderbolt Cable design and test results of its characteristics and reliability.

## 2. Design Outline of Optical Thunderbolt Cable

**Photo 1** shows the appearance of the Optical Thunderbolt Cable and element technologies that constitute this cable. This section describes the design outline of these element technologies.

**Table 1.** Comparisons between Thunderbolt and USB

Standard	Thunderbolt	USB2.0	USB3.0
Transmission speed	Bidirectional 10Gb/s 2 lanes	Bidirectional 480Mb/s 1 lane	Bidirectional 5Gb/s 1 lane
Cable length	Max. 3m (Sumitomo electrical cable) Max. 30m (Sumitomo optical cable) *Optical cable doesn't support power delivery.	5m (max.) *electrical cable only	3m (max.) *electrical cable only
Feature	<ul style="list-style-type: none"> <li>· Conforms to two protocols for data and image transmission. (PCI Express and DisplayPort)</li> <li>· Can be daisy-chained</li> <li>· Maximum power supply: 12W (*Some PCs support only 10W.)</li> </ul>	<ul style="list-style-type: none"> <li>· Data transmission</li> <li>· Tree connection</li> <li>· Maximum sharing power: 2.5W</li> </ul>	<ul style="list-style-type: none"> <li>· Data transmission</li> <li>· Tree connection</li> <li>· Maximum sharing power: 4.5W</li> </ul>
Established	2011	2000	2008

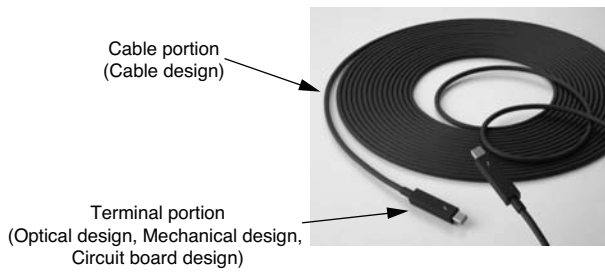

Photo 1. Optical Thunderbolt Cable and its element technologies

### 2-1 Cable design

The Optical Thunderbolt Cable has four optical fiber cores to provide two lanes of 10 Gb/s bidirectional transmission channels. For enhanced cable robustness, the optical fiber cores and aramid yarn are enclosed in plastic tube. Moreover, the outer jacket and plastic yarn are arranged around it. The cable diameter is 4.2mm.

The Optical Thunderbolt Cable is applied not only to video equipment for professionals, but also to electric devices for general consumers. Therefore, the cable has to withstand unexpected wear and tear such as cable pinching. As shown in Photo 2, even if the cable is pinched 180

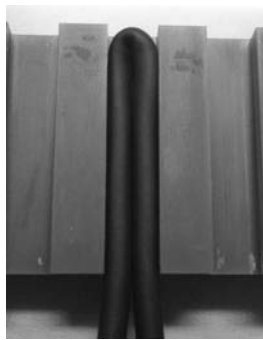

Photo 2. Cable pinch test

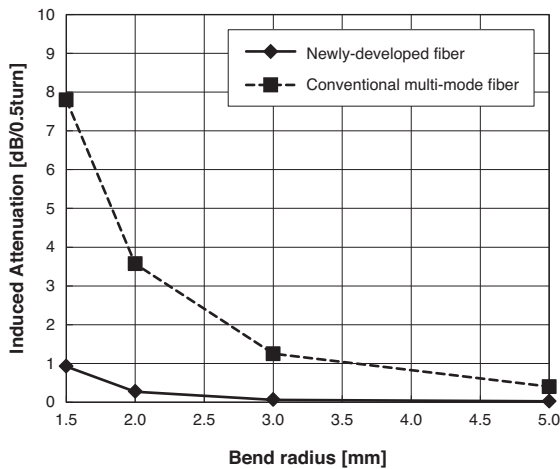

Fig. 1. Bending loss of the newly developed optical fiber

degrees, the optical fibers need to stay intact in order to maintain communication. Figure 1 shows the bending loss of a newly developed optical fiber for the Optical Thunderbolt Cable. Figure 2 shows the calculated failure probability. The newly developed fiber shows less bending loss and smaller failure probability than those of a conventional multi-mode fiber when pinched (R=2mm). Our Optical Thunderbolt Cable can be used even when folded in half, as shown in Photo 2.

Figure 3 shows the compression test results. This test assumes that the cable is rolled over by an office chair. The cable was rotated by 45 degrees. The induced attenuation is within 0.2 dB at each position, and our cable showed good compression characteristics. Table 2 shows the other cable characteristics. It was confirmed that our cable showed high durability in mechanical and thermal reliability.

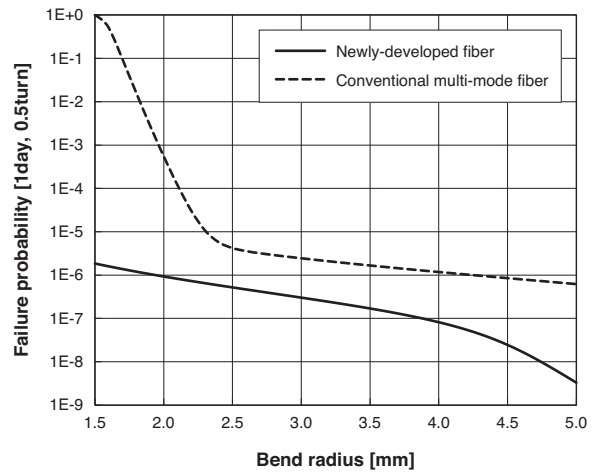

Fig. 2. Calculated failure probability of the newly developed fiber

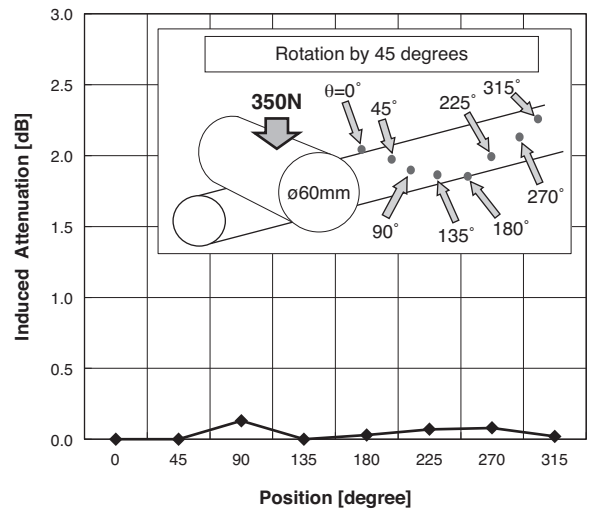

Fig. 3. Compression Test Result

**Table 2.** Cable characteristics

Item	Condition	Result (Induced Attenuation)
Tensile	100N	<0.2dB
Compression	R30mm, 350N	<0.2dB
Impact	0.5kg, 15cm	<0.2dB
Flexing	R15mm, $\pm 90^\circ$ , 1000cycles	<0.2dB
Twist	$\pm 180^\circ/0.3m$ , 1000cycles	<0.2dB
Knot	50N	<0.2dB
Temperature cycling	-20degC to 85degC, 5cycles	<0.2dB
Flame resistance	UL VW-1	Pass

## 2-2 Optical design

Figure 4 shows the schematic diagrams of the optical components between the optical fibers and the circuit board mounted with optoelectronic devices, VCSEL\*/PD\*. Each VCSEL/PD is optically coupled with the corresponding optical fiber by the lens module. The optical axes of the VCSEL/PD are vertical to the circuit board, and those of the optical fibers are parallel to the board. To achieve the coupling between them, each of axes is turned 90 degrees with the 45-degree angled surface of the lens module. Also, 8 aspherical lenses formed on the edge and the bottom sides of the lens module contribute to coupling.

In order to obtain sufficient coupling efficiency between the optical fiber and the VCSEL/PD, the VCSEL/PD needs to be mounted on the designed position and the lens module is required to be bonded accurately to these elements. Figure 5 shows the measurement results of 200 modules we evaluated. Figures 5 (a) and (b) show the posi-

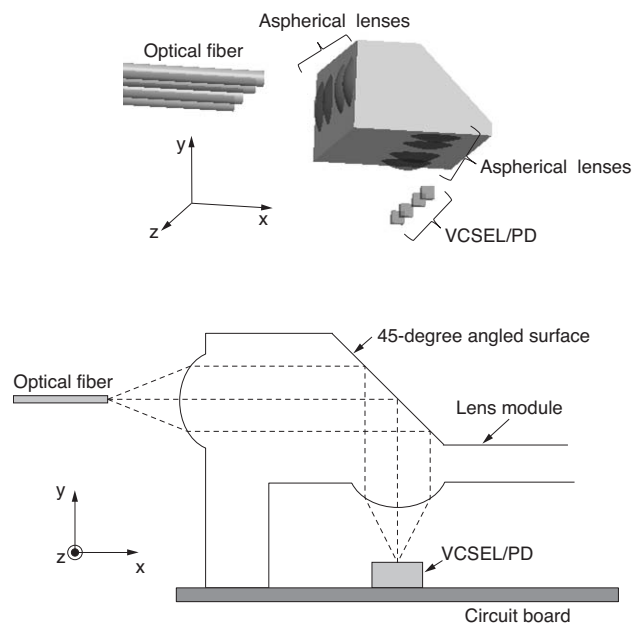

**Fig. 4.** Schematic diagrams of optical components

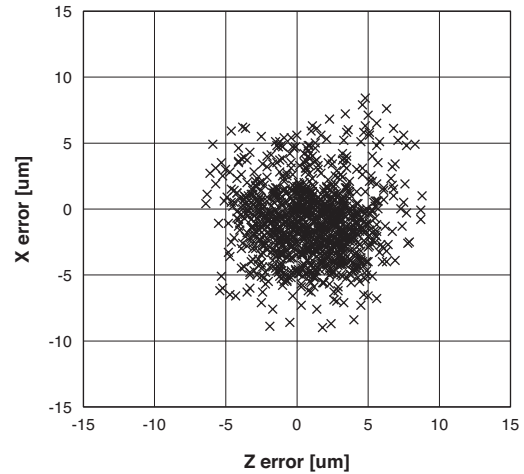

**(a) VCSEL/PD error**

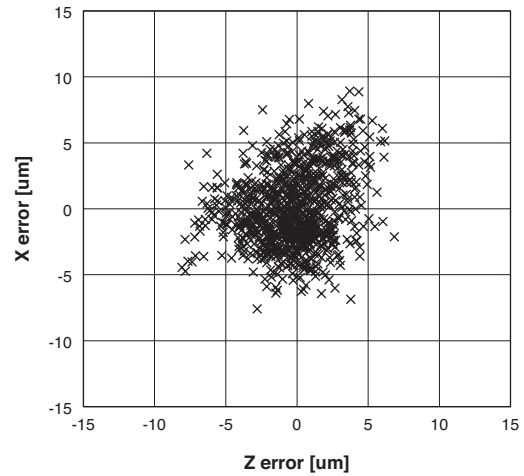

**(b) Lens module error**

**Fig. 5.** Measurement results of positioning errors

tioning errors of VCSEL/PD and lens modules, respectively. Positional accuracy of less than 10  $\mu\text{m}$  was achieved.

Considering the above-mentioned results and the dimensional accuracy of all components, the aspherical lenses have been optimized to give sufficient coupling efficiency under any conditions for tolerated dimensional and positional errors.

## 2-3 Mechanical design and thermal analysis results

Figure 6 shows the structure of the connector termination schematically. A PCBA with a Thunderbolt connector is shielded by a metal shell and then covered with plastic parts. The metal shell can shield radiation noise from the PCBA and dissipate heat on the PCBA efficiently. On the connecting portion between the cable and metal shell, the cable is fixed tightly to the metal shell by winding the tension member of the optical fibers around the metal flange.

From the viewpoint of product reliability, the most important issue is degradation failure of VCSEL by heat generation. It must not overheat even at the upper limit of operating temperature. Figure 7 shows an example of the temperature distribution on a connector terminal. It indicates that heat of VCSEL dissipates effectively through me-

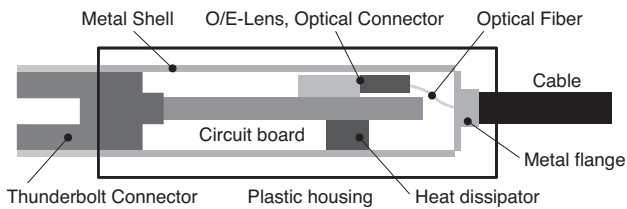

Fig. 6. Schematic view of terminal structure

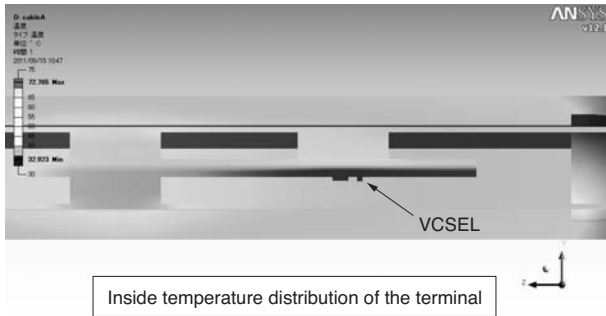
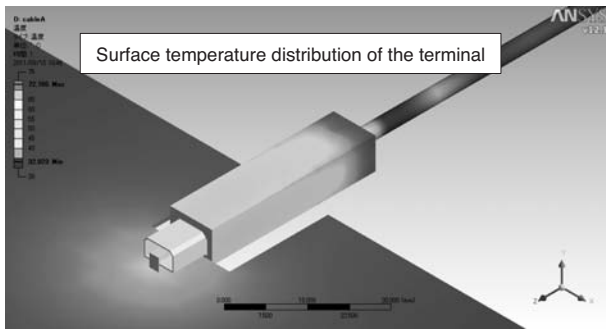

Fig. 7. Thermal analysis at upper limit of operating temperature

chanical parts and we confirmed that we can keep it at low enough temperature.

**2-4 Circuit board design and optical characteristics**

Figure 8 shows the function block diagram of the cable terminal portion. The interface of the Thunderbolt connector side uses an electrical signal. Meanwhile, an optical signal is used for communication inside the cable via VCSEL/PD mounted on the circuit board of the terminal portion.

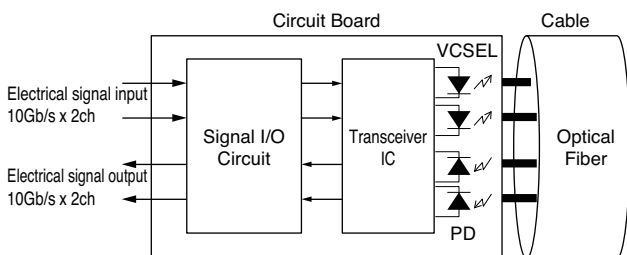
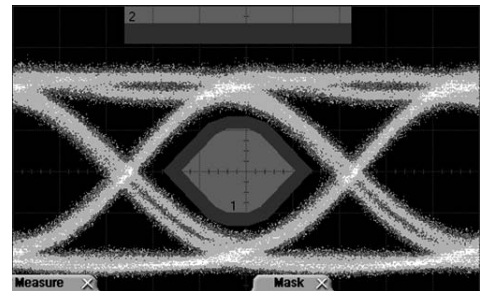

Fig. 8. Function block diagram

Figure 9 shows the optical output waveform inside the cable. It has a good eye opening, indicating a high quality waveform.

Figures 10 and 11 show the temperature characteristics of optical output power and extinction ratio<sup>\*8</sup>, respectively. Both parameters show good temperature stability, which indicates that the drive current of the VCSEL is controlled appropriately and a stable optical signal is transmitted inside the cable over the whole temperature range when the Optical Thunderbolt Cable is used.



Test condition : 10.3125Gb/s, PRBS2^31-1

Fig. 9. Optical output waveform

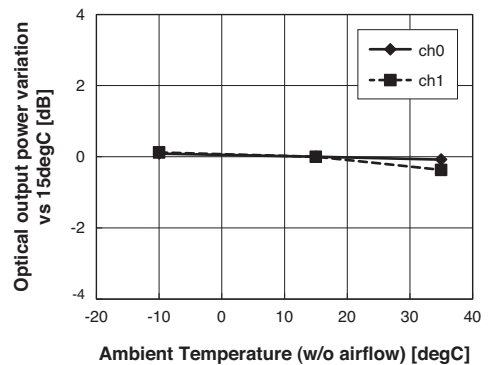

Fig. 10. Temperature dependence of optical output power

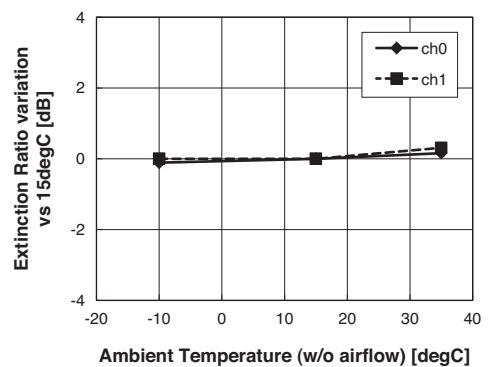

Fig. 11. Temperature dependence of extinction ratio

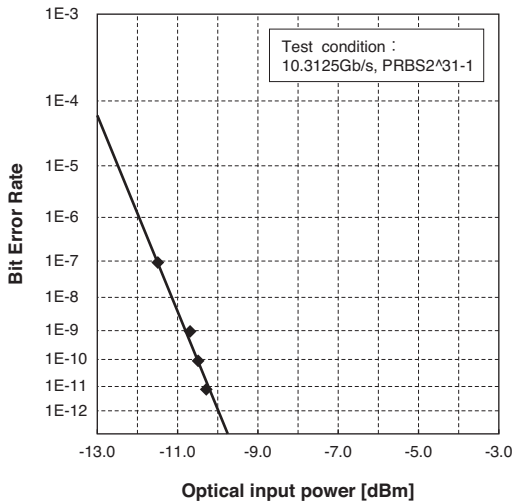

Fig. 12. Receiver sensitivity characteristics

Figure 12 shows an example of the receiver sensitivity characteristics. Minimum sensitivity (@1E-12) is around -10 dBm, which indicates that there is enough margin when considering the degradation of receiver sensitivity by optical power loss and mode dispersion due to cable transmission and bending.

### 3. Transmission Characteristics of Optical Thunderbolt Cable

Figure 13 shows a test setup for the transmission characteristics of the Optical Thunderbolt Cable. As the cable input waveform depends on the output waveform from the host side machine connected to the cable, it was distorted purposely to simulate the worst condition. The cable output waveform has a good eye opening and the bit error rate tester confirmed error free transmission.

Figure 14 shows a setup for the function test using Thunderbolt machines. Although this figure is an example of notebook PC and hard disk drive, normal operation has been confirmed when other Thunderbolt machines such as a Thunderbolt Display are connected to it.

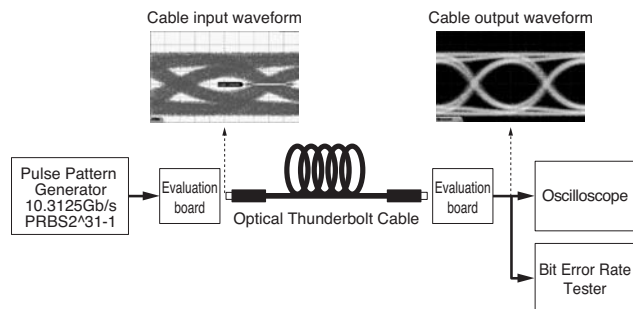

Fig. 13. Test setup for transmission characteristics

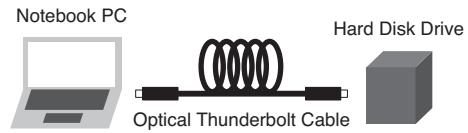

Fig. 14. Setup for Thunderbolt function test

## 4. Reliability Test Results of Optical Thunderbolt Cable

Table 3 shows reliability test results. Checking performance with Thunderbolt devices was chosen as the criterion. The cable showed normal characteristics after these tests, which assures that the cable is reliable enough for use.

Table 3. Reliability test results

Test Category	Item	Condition	Criterion	Result
Environmental test	High temperature operating life	80degC, 2,000 hours	Thunderbolt devices show no problems during the performance check before and after each test; and no abnormal appearance is found.	Pass
	Temperature and humidity cycle	RH95% at 25 to 85degC 12 cycles		Pass
	Thermal shock	-55 to 85degC 10 cycles (1 hr/cycle)		Pass
Mechanical test	Vibration	50 to 2,000Hz, Amplitude 1.52mm XYZ directions, 12 times with 20 min each		Pass
	Mechanical shock	1,000G, 0.5ms XYZ directions, 6 times		Pass
Electrical characteristics test	EMI	30MHz to 26.5GHz PRBS2^31-1	FCC, CE, VCCI	Pass
	ESD	Air and contact discharge with 8kV	No abnormal performance	Pass

## 5. Conclusion

Based on Intel's technical specifications, we have developed an Optical Thunderbolt Cable by drawing on its optical fiber and module technologies, and received the world's first product certification. The Optical Thunderbolt Cable has the capability of long-distance transmission of up to 30 meters, excellent robustness, durability and flexibility when using specially designed optical fiber. In the future, high-speed interfaces, as typified by Thunderbolt, will grow fast along with the increase of data traffic, and the application of active optical cable will further increase for consumer electronics devices.

## 6. Acknowledgements

We thank Intel Corporation for their great deal of support during this development.

### Technical Terms

- \*1 Peripheral Component Interconnect (PCI) Express: One of the interface standards for communication inside a PC. It is also a standard specification for expansion of input/output interfaces. It was established by the Peripheral Component Interconnect Special Interest Group (PCI-SIG) in 2002.
- \*2 DisplayPort: One of the interface standards for digital image signals output. It was established by the Video Electronics Standards Association (VESA) in 2006.
- \*3 Docking station: A device that expands the notebook PC functionality. It allows notebook PCs to have performance comparable with that of desktops while ensuring their compactness and portability. The docking station for Thunderbolt converts signals between PCI Express and other conventional interfaces.
- \*4 Daisy chain: A connection method that connects devices sequentially.
- \*5 Graded Index (GI) fiber: One of the multimode fiber. It is designed to reduce the difference of propagation time among modes by controlling distribution of the refractive index.
- \*6 Vertical Cavity Surface Emitting Laser (VCSEL): One of the semiconductor laser diodes. It features the laser beam emitted vertically from the top surface and low power consumption. It is widely used in consumer devices, such as mouse computers and laser printers in addition to communication devices.
- \*7 Photo diode (PD): One of the photo detectors using a semiconductor diode.
- \*8 Extinction ratio: A ratio of optical power of "1" level and "0" level of a digitally modulated optical signal.
- \*9 Mode dispersion: A phenomenon in which the signal propagation time differs depending on the modes of a multimode fiber. It affects fiber output waveform.

- Thunderbolt and Thunderbolt logo are trademarks or registered trademarks of Intel Corporation in the U.S. and other countries.
- PCI Express is a trademark or registered trademark of the PCI-SIG in the U.S. and other countries.

### References

- (1) <http://global-sei.com/ewp/E/thunderbolt/index.html>
- (2) <https://thunderbolttechnology.net/>
- (3) Wataru Sakurai et. Al., "Development of High-Speed 10-Gb/s Interface Cable 'Thunderbolt Cable'" SEI Technical Review, No.75, Oct. 2012.

### Contributors (The lead author is indicated by an asterisk (\*).)

#### Y. MAEDA\*

- Assistant Manager, Optical Communications R&D Laboratories

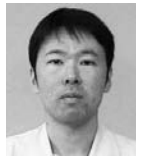

#### M. HARUMOTO

- Assistant General Manager, Optical Communications R&D Laboratories



#### T. SHIMAZU

- Assistant General Manager, Optical Communications R&D Laboratories



#### Y. HOMMA

- Optical Communications R&D Laboratories



#### M. TAMURA

- Senior Manager, Sumitomo Electric Wire Inc.



#### Y. CHIGUSA

- Ph.D,  
Chief Engineer, Electric Wire Division

