



SUMITOMO RECOMMENDED PROCEDURE

SRP SP-F04-026

FutureFLEX®

TANDEM BLOWING PROCEDURE

<u>PARA.</u>	<u>CONTENTS</u>
1.0	General
2.0	Safety Precautions
3.0	Reference Documents
4.0	Equipment / Tools Required
5.0	Equipment Layout
6.0	Blowing Head Equipment Set-up
7.0	First Blowing Operation
8.0	Tandem Blowing Operations
9.0	Completing Blowing Operations
10.0	Completing Installation – At Entry Point FTU
11.0	Completing Installation – At Point B TDU
12.0	Completing Installation – At Exit Point FTU
	TABLE I – Standard Fiber Bundle Blowing Distances



SUMITOMO ELECTRIC LIGHTWAVE CORP.

78 TW Alexander Drive, Research Triangle Park, NC 27709

(919) 541-8100 or 1-800-358-7378

www.futureflex.com

SEL is a Member of the Sumitomo Electric Industries, Ltd. Group

Sumitomo Electric Lightwave reserves the right to improve or modify these specifications without notice.

1.0 General

1.1 There are three (3) recommended Extended Blowing techniques that can be used to install FutureFLEX Air Blown Fiber (ABF) fiber bundles beyond their standard blowing distances or through difficult tube routes (i.e.: those with numerous tight bends):

- Tandem Blowing
- Mid-Span Blowing with a Figure 8
- Segment Blowing with a Figure 8

1.2 **Table I** provides information on *Standard Blowing Distances Using One (1) Blowing Head*. This data can be very helpful in determining if an Extended Blowing technique will be required or should be considered.

1.3 This Sumitomo Recommended Procedure (SRP) describes the steps necessary to perform the Tandem Blowing Procedure.

1.4 Overview - A Tandem Blowing operation requires two (2) Blowing Head Equipment Kits.

1.4.1 The first Blowing Head, with fiber bundle reel, is set up at the start of the tube span (Point A).

1.4.2 The second Blowing Head, without fiber bundle reel, is set up at an intermediate point in the tube span (Point B).

1.4.3 The first Blowing Head is activated to install fiber bundle from Point A to Point B.

1.4.4 When the fiber bundle arrives at Point B, blowing operations are temporarily stopped and the exposed end of the fiber bundle is loaded into the second Blowing Head.

1.4.5 When ready, both Blowing Heads are activated and operated in tandem (together) to simultaneously move fiber bundle along from Point A to Point B and from Point B to the end of the tube span (Point C).

1.5 A Tandem Blowing operation can effectively double standard fiber bundle blowing distances.

1.5.1 It is a highly recommended Extended Blowing technique because it requires only minimal handling and exposure of the fiber bundle since the exposed fiber bundle is fed directly into the second Blowing Head with no Figure 8 required.

1.5.2 Since the two Blowing Heads will be at physically different locations, good communication and coordination between operating crews is essential.

1.6 Tandem Blowing can be performed with various pressure sources; Nitrogen Cylinder, Compressed Air Cylinder, or Air Compressor.

1.7 A minimum of four (4) personnel are required to perform this procedure.

- Blowing Head #1 Operator
- Blowing Head #2 Operator
- Blowing Head #2 Assistant
- Installer

1.8 Before installing a fiber bundle, the tube span must successfully pass the Tube Pressure and Tube Obstruction Tests. See Sumitomo Recommended Procedures SRP SP-F04-003 and SRP SP-F04-004.

2.0 Safety Precautions

2.1 Pressurized Nitrogen – The use of inert (nonflammable) pressurized nitrogen (N₂) gas presents several safety concerns.

2.1.1 N₂ is a simple asphyxiate. If large amounts of nitrogen are released into a confined area, the nitrogen can displace the amount of oxygen in air necessary to support life. This can result in a loss of balance, dizziness, rapid reduction in the ability to perform movements, reduced consciousness of surroundings, as well as other symptoms that are included in the MSDS (Material Safety Data Sheet) available upon request from the Gas Supplier. It is recommended that pressurized nitrogen only be released into a well-ventilated area.

2.1.2 When using pressurized nitrogen, there are no risks related to fire, reactivity, or other special hazards. Nitrogen is not listed as a carcinogen by NTP, IARC, or OSHA.

2.2 Compressed Air – The use of nonflammable pressurized compressed air (Atmospheric Air), either from a cylinder / bottle or air compressor, presents no safety concerns.

2.2.1 Air is nontoxic and necessary to support life. There are no ventilation concerns.

2.2.2 Compressed Air at high pressures does present an unusual fire and explosive hazard in that it will accelerate the burning of materials to a greater rate than they would burn at normal atmospheric pressure.

2.2.3 When using pressurized air, there are no risks related to fire, reactivity, or other special hazards. Air is not listed as a carcinogen by NTP, IARC, or OSHA. An MSDS (Material Safety Data Sheet) is available upon request from the Gas Supplier.

2.3 Pressurized Gas Cylinders / Bottles – Transporting and handling pressurized gas cylinders presents several safety concerns.

2.3.1 Any pressurized gas cylinder is dangerous if damaged. Gas bottles must be properly capped when being transported and stored. Gas bottles must be secured in a stable pressure bottle dolly or chained to structure when uncapped for use.

2.3.2 A full size 300 cubic foot volume gas bottle weighs approximately 160 lbs. Two personnel should accomplish any manual lifting or moving of a bottle. Exercise care and use proper lifting techniques.

2.4 Blowing Head Equipment Transit Case – Transporting and handling the Blowing Head Equipment Transit Case presents several safety concerns.

2.4.1 The Transit Case weighs approximately 70 lbs. Normal transport is accomplished by pushing / pulling the Transit Case using its retractable handle and built-in wheels.

2.4.2 It is recommended that two personnel accomplish any manual lifting or moving of the Transit Case. Exercise care and use proper lifting techniques.

3.0 Reference Documents

3.1 Sumitomo Recommended Procedure, *FutureFLEX Blowing Equipment Set-up Procedure* SRP SP-F04-001.

3.2 Sumitomo Recommended Procedure, *FutureFLEX Fiber Bundle Installation Procedure* SRP SP-F04-002.

3.3 Sumitomo Recommended Procedure, *FutureFLEX Tube Pressure Testing Procedure* SRP SP-F04-003.

3.4 Sumitomo Recommended Procedure, *FutureFLEX Tube Obstruction Testing Procedure* SRP SP-F04-004.

4.0 Equipment / Tools Required

The following equipment and tools are required to complete this procedure.

4.1 Nitrogen Cylinder (Installer provided)

- Dry Industrial Grade Nitrogen; preferred pressure source
- Inert (nonflammable) gas
- Dry or with no more than 4 ppm moisture content (H₂O)
- Oil / contaminant free output
- 300 cu. ft. (approx.) volume bottle size recommended
- 2000-to-2500 psi (approx.) pressure charge

Note: Typically, one 300 cu. ft. bottle of nitrogen will be required to install (approx.) 3000' - 4000' of fiber bundle. This "conservative estimate" can vary depending upon tube route orientation, fiber bundle size, tube cable type, and operating practices.

4.1.1 **Special Note:** The total number of Gas Bottles required to accomplish Tandem Blowing operations must be considered. Typically, at least two (2) bottles (maybe more) will be needed at Point A Blowing Head #1 location and one (1) bottle (maybe two) at Point B Blowing Head #2 location; total three (3) bottles

minimum. Very long or tortuous tube span routes may require more.

4.1.2 Special Note: The use of a Dual Tank Set-up, especially at Point A Blowing Head #1 location, is strongly recommended to support uninterrupted extended blowing operations. Depending on total tube span length, a Dual Tank Set-up may also be beneficial at Point B Blowing Head #2 location. See Sumitomo Recommended Procedures SRP SP-F04-001 and SRP SP-F04-002 for details.

4.2 Pressure Regulator Assembly with 8mm Tubing Adapter (BEREG01 Single-Stage or BEREG02 Single-Stage) (Installer provided and strongly recommended).

4.3 Dual-Tank Isolation Valve Kit (BEISOV1) (Installer provided and strongly recommended).

4.4 Two (2) Blowing Head Equipment Kits (BE200RM, BE200RS, or BE200RY). See Sumitomo Recommended Procedure SRP SP-F04-001 for details.

4.5 Tube Couplings (DE08MC2) (Installer provided).

4.6 Tube Cap (DE08MA) (Installer provided).

4.7 Fiber Bushings (FT2MFB or FT3MFB) (Installer provided); two required.

4.8 Two (2) Cylinder Adapters (BEREGCA) (Installer provided); required if using Compressed Air Cylinders as pressure source.

4.9 Soft, clean cotton gloves or similar.

4.10 Alternate Pressure Source – Although bottled nitrogen is the preferred pressure source because of its cleanliness, general convenience, inexpensive cost, and ease of portability, compressed air from either a Compressed Air Cylinder or an Air Compressor can be used as an alternate pressure source.

4.11 Compressed Air Cylinder (Installer provided)

- “Dry Grade” Compressed Air
- Nonflammable gas (atmospheric air)
- Dry or with no more than 10 ppm moisture content (H₂O)
- Oil / contaminant free
- 300 cu. ft. (approx.) volume bottle size recommended
- 2000-to-2500 psi (approx.) pressure charge

Note: Different types or “grades” of Compressed Air are available. The “purer” grades with such names as Zero Grade, Vehicle Emission Grade, Scientific Grade, and Accurate Grade undergo additional refining processes so they contain fewer impurities (hydrocarbons) and have less moisture content. It is not necessary to use these “purer” grades of air for blowing operations.

Note: Performance-wise, Compressed Air supplied in a Cylinder performs the same as Nitrogen. There are no differences in the blowability of fiber bundle nor operation of the Blowing Head.

Note: Typically, one 300 cu. ft. bottle of Compressed Air will be required to install (approx.) 3000' - 4000' of fiber bundle. This “conservative estimate” can vary depending upon tube route orientation, fiber bundle size, tube cable type, and operating practices.

Important Note: Compressed Air Cylinders are supplied with a Female left-hand thread Bottle fitting (CGA-590). Pressure Regulators BEREG01 or BEREG02 supplied in the Blowing Head Equipment Kit have a Male right-hand thread Nut (CGA-580). A CGA-590 Industrial Air Cylinder-to-CGA-580 Nitrogen Regulator Cylinder Adapter is therefore required to connect the Pressure Regulators to the Bottle fitting. One (1) Cylinder Adapter is required for each Pressure Regulator used. **See Fig. 1.**

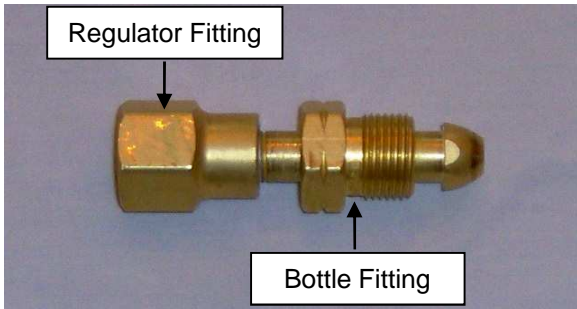

Figure 1

CGA-590 Industrial Air Cylinder-to-CGA-580
 Nitrogen Regulator Cylinder Adapter

- Output oil / contaminant free
- Output flow rate (capacity) at least 12 scfm
- Output pressure at least 200 psi

Note: If an Air Compressor is to be used, consider the following potential issues first. Power source / requirements? Physical size of Compressor? Portability? Distance Compressor must be set up from Blowing Head? Fittings necessary to connect Compressor output to a Pressure Regulator? Noise if use indoors?

5.0 Equipment Layout

4.12 Air Compressor (Installer provided)

- Output dry or with no more than 10 ppm moisture content (H₂O); often requires use of a Secondary Dryer

5.1 See Fig. 2 for a typical Tandem Blowing Equipment layout.

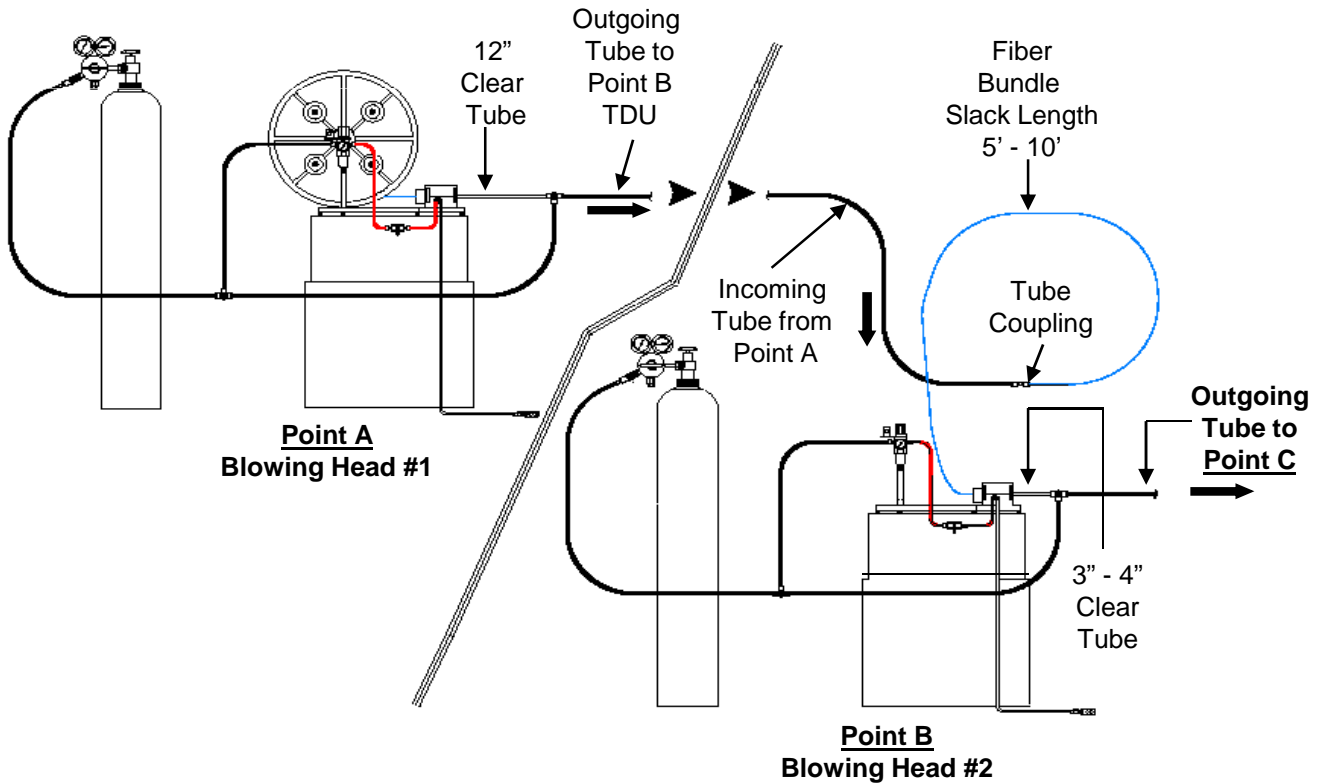

Figure 2

Tandem Blowing Equipment Layout

6.0 Blowing Head Equipment Set-up

Note: The steps below assume a tube span that begins at Point A, runs through Point B, and terminates at Point C. Point A contains the entry point Fiber Termination Unit (FTU). Point B contains a mid-span Tube Distribution Unit (TDU). Point C contains the exit point FTU.

CAUTION: Before installing fiber bundle, verify Tube Pressure and Tube Obstruction Test Procedures (Sumitomo Recommended Procedures SRP SP-F04-003 and SRP SP-F04-004) have been successfully accomplished from Point A to Point C.

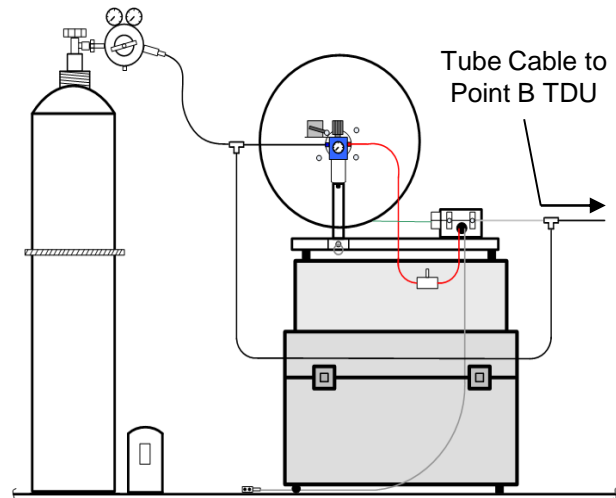

Figure 3

Blowing Head #1 set up at Point A per normal procedures

6.1 Establish communications between Blowing Head Operator #1 located at Point A, Blowing Head Operator #2 and Assistant located at Point B, and Installer located at Point C.

6.2 At Points A, B, and C, locate and identify correct tube cable and tube scheduled for fiber bundle installation.

6.3 Evaluate all fiber bundle entry and exit point locations. Ensure they are well ventilated to disperse nitrogen gas released during installation operations. If necessary, relocate Blowing Equipment to ventilated areas and use jumper tubing to reach entry point FTU and mid-span TDU. If necessary, use jumper tubing at exit point FTU and extend tube span to a ventilated area. If required, provide auxiliary means of ventilation.

6.4 At Point A, set up Blowing Head #1 and fiber reel in accordance with Sumitomo Recommended Procedure SRP SP-F04-001. **See Fig. 3.**

6.4.1 Verify Fiber Bundle Drive Wheels and Air Seals are in good shape / do not show signs of wear. Change if required.

6.4.2 Apply Air Motor Cleaner Fluid to Blowing Head #1 Air Motor.

6.4.3 Consider using Dual Tank Set-up at Point A.

6.5 At Point B, set up Blowing Head #2 in accordance with Sumitomo Recommended Procedure SRP SP-F04-001 with the following exceptions. **See Fig. 4.**

6.5.1 No fiber reel is used.

6.5.2 Push-fit only a 3" - 4" length of 8mm Clear Tube into one side of Second Tee Coupling. (This short length reduces how much tubing has to be stored later.)

6.5.3 Verify Fiber Bundle Drive Wheels and Air Seals are in good shape / do not show signs of wear. Change if required.

6.5.4 Apply Air Motor Cleaner Fluid to Blowing Head #2 Air Motor.

6.5.5 Consider using Dual Nitrogen Tank Set-up at Point B.

6.6 At Point B TDU, uncouple tube span and perform following steps. **Refer to Fig. 4.**

6.6.1 Install jumper tubing between incoming tube from Point A and Blowing Head #2 area.

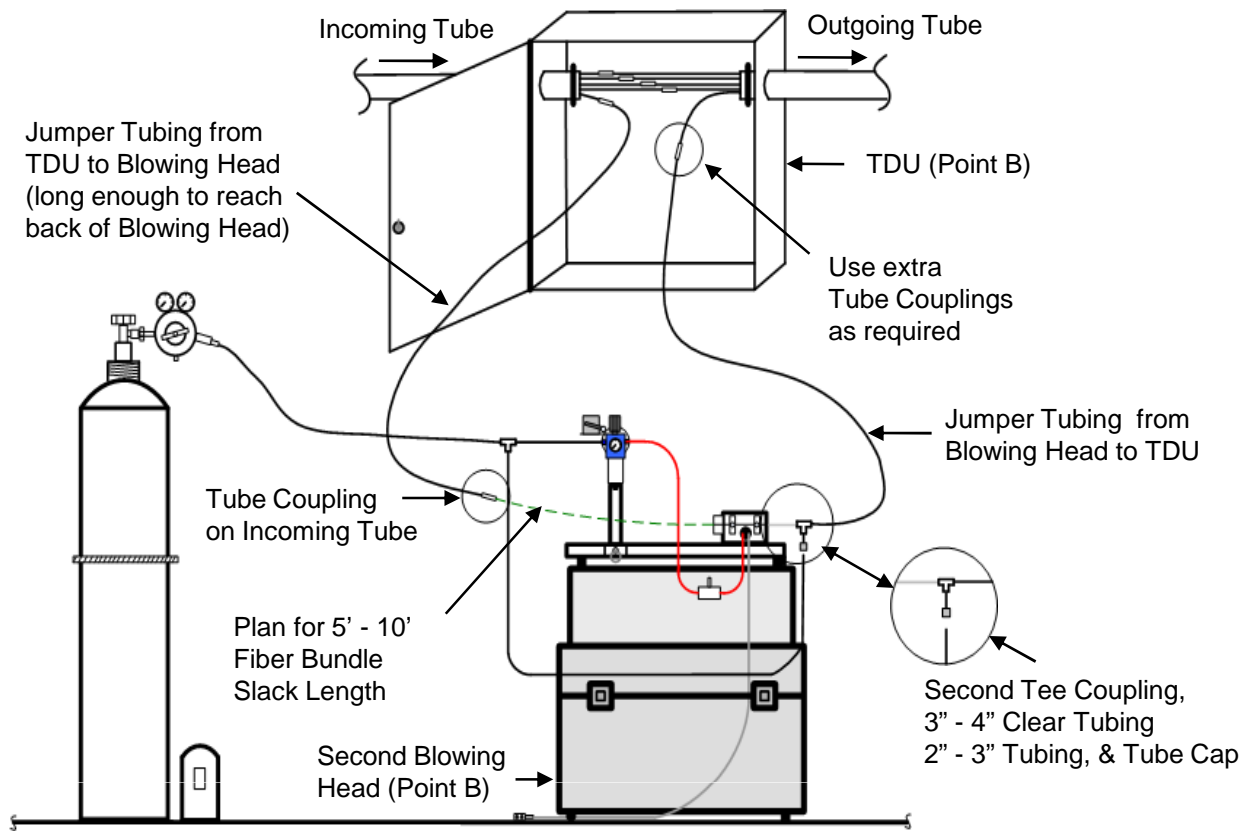

Figure 4
 Blowing Head #2 Head set up at Point B

6.6.2 **Critical Step.** Verify a Tube Coupling is installed on end of incoming jumper tubing from Point A.

6.6.3 Install jumper tubing between Second Tee Coupling of Blowing Head #2 and outgoing tube to Point C.

6.6.4 **Key Step.** Test fit and verify all tubing used can be coiled and neatly stored inside Point B TDU after blowing operations are completed. This step must be done before blowing operations begin. **See Fig. 5.**

6.5.5 After the Jumper Tubing test fit is done, uncouple tubes and get ready to receive fiber bundle.

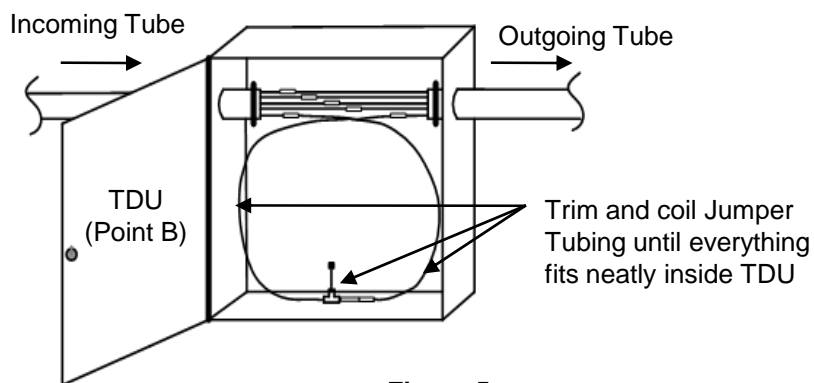

Figure 5
 Test Fitting all Jumper Tubing inside Point B TDU

7.0 First Blowing Operation

7.1 At Point B TDU, uncouple tube span and ensure Tube Coupling is installed on incoming tube from Point A.

7.2 Blowing Head #1 Operator opens Bottle Supply Valve, sets initial operating pressures, pressurizes Point A-to-Point B tube segment, and obtains verification that airflow exists at Point B TDU. See Sumitomo Recommended Procedure SRP SP-F04-002.

7.3 When ready, install fiber bundle from Point A to Point B in accordance with Sumitomo Recommended Procedure SRP SP-F04-002.

7.4 When fiber bundle reaches Point B TDU, Blowing Head #2 Operator instructs Blowing Head #1 Operator to slow fiber bundle movement.

CAUTION: Handle exposed fiber bundle with care and wear soft, clean cotton gloves or similar protection to avoid contaminating fiber bundle jacket.

7.5 Assistant at Blowing Head #2 handles and supports fiber bundle as it exits tube.

Note: A 5' - 10' exposed length of fiber bundle is recommended. This footage will be used as a slack loop when Tandem Blowing operations are started.

7.6 When a 5' - 10' slack loop length of fiber bundle is available at Point B TDU, Blowing Head #2 Operator instructs Blowing Head #1 Operator to close Motor Rate Control Valve and stop fiber bundle movement. **Refer Fig. 4.**

7.7 Do not close Bottle Supply Valve at Blowing Head #1. Leave Air Flow pressure flowing through Point A-to-Point B tube segment.

Note: It is suggested to check Blowing Head #1 Bottle supply pressure at this time. If low, this is the best time to change to a full bottle to avoid interrupting Tandem Blowing operations later.

8.0 Tandem Blowing Operations

8.1 Blowing Head #2 Operator loads exposed end of fiber bundle into Blowing Head #2 in accordance with Sumitomo Recommended Procedure SRP SP-F04-001. Work quickly to avoid wasting Blowing Head #1 gas supply. **See Fig. 6.**

8.2 Assistant prepares to handle slack loop footage and guide exposed fiber bundle into back of Blowing Head #2.

8.3 Blowing Head #2 Operator assumes control of Tandem Blowing operation.

8.4 Blowing Head #2 Operator opens Bottle Supply Valve at Blowing Head #2, sets initial operating pressures, pressurizes Point B-to-Point C tube segment, and obtains verification that airflow exists at exit point FTU. See Sumitomo Recommended Procedure SRP SP-F04-002.

8.5 Verify Point A-to-Point B tube segment is still pressurized; Air Flow pressure exists.

8.6 When ready, Blowing Head #2 Operator instructs Blowing Head #1 Operator to begin blowing operations.

8.7 Blowing Head #1 Operator slowly opens Motor Rate Control Valve and starts fiber bundle movement through the Point A-to-Point B tube segment again.

8.8 Blowing Head #2 Operator and Assistant watch for movement of exposed fiber bundle by observing slack loop footage.

8.9 When slack loop footage begins to increase, Blowing Head #2 Operator slowly opens Motor Rate Control Valve and starts fiber bundle installation while Assistant carefully guides fiber bundle into back of Blowing Head. **Refer to Fig. 6.**

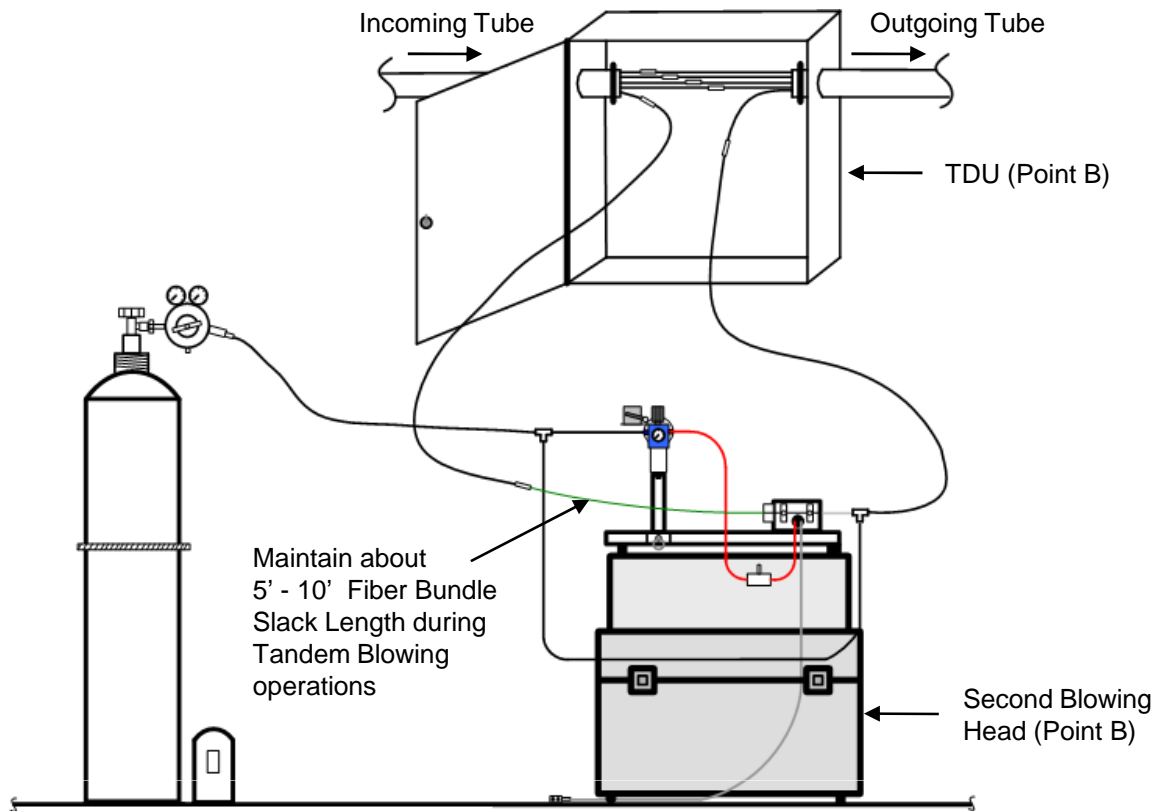

Figure 6
Tandem Blowing Operations at Blowing Head #2 Location
Key Point: Adjust blowing speed to maintain 5' – 10' Fiber Bundle Slack Length

8.10 Blowing Head #2 Operator tries to match fiber bundle installation speed with Blowing Head Operator #1.

8.10.1 **Critical Step.** Always maintain open communication lines between the two Blowing Head locations.

8.10.2 Should one Blowing Head operation slow down, speed up, or stop, the other Blowing Head operation must follow suit immediately.

8.10.3 Always maintain a sufficient length of fiber bundle slack loop footage at Blowing Head #2 to avoid damaging fiber bundle.

8.10.4 If possible, slowly increase installation speed of both Blowing Heads to a comfortable level but always maintain sufficient slack length footage behind Blowing Head #2 to avoid damaging fiber bundle.

9.0 Completing Blowing Operations

9.1 Installer at Point C informs both Blowing Head Operators when fiber bundle reaches exit point FTU.

9.2 Both Blowing Head Operators adjust Motor Rate Control Valves to slow fiber bundle movement.

9.3 A 10' - 15' exposed length of fiber bundle is recommended for fiber termination purposes; more or less if required / desired. Installer at Point C informs both Blowing Head Operators when enough fiber bundle length is available at exit point FTU.

9.4 Blowing Head #1 Operator then closes Motor Rate Control Valve to stop fiber bundle payoff from reel. Close Bottle Supply Valve and wait for tube span to de-pressurize before opening Blowing Head.

9.5 Blowing Head #2 Operator continues to slowly install fiber bundle, decreasing exposed slack loop footage. Assistant continues to help guide fiber bundle and jumper tubing toward back of Blowing Head.

9.6 **Key Step.** Blowing Head #2 Operator closes Motor Rate Control Valve and stops fiber bundle movement when Tube Coupling is about 1 foot behind back of Blowing Head #2. **See Fig. 7A.**

9.7 Do not close Bottle Supply Valve. Maintain Air Flow pressure in Point B-to-Point C tube segment. Work quickly to complete next step.

9.8 Release rear latch on Blowing Head #2, remove Fiber Guides, and re-engage rear latch.

CAUTION: During next step, go slowly to avoid damaging fiber bundle.

9.9 Blowing Head #2 Operator slowly opens Motor Rate Control Valve and moves fiber bundle and Tube Coupling into back of Blowing Head #2. **See Fig. 7B.**

9.9.1 Blowing Head Operator #2 and Assistant must work together to avoid damaging fiber bundle during this step.

9.9.2 **Critical Step.** Try to draw Tube Coupling into back of Blowing Head as far as possible but do not "jam" tubing and fiber bundle.

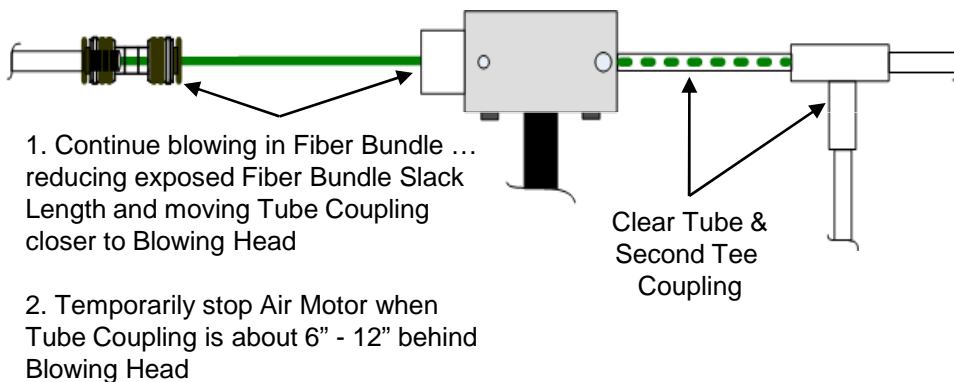

Figure 7A

Bring Jumper Tubing up to About 1-Foot Behind Back of Blowing Head

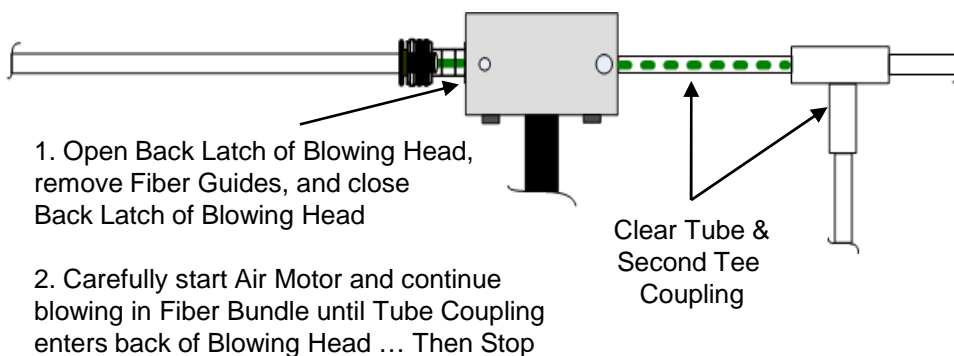

Figure 7B

Remove Fiber Guides and Draw Tube Coupling into Back of Blowing Head

9.10 Blowing Head #2 Operator closes Motor Rate Control Valve and stops fiber bundle movement when Tube Coupling is drawn into back of Blowing Head.

9.11 Close Bottle Supply Valve. Work quickly to complete next step.

9.12 Do not wait for Point B-to-Point C tube segment to fully de-pressurize. Be aware that residual Air Flow pressure still exists in tube segment. Carefully open Blowing Head #2 as

soon as possible. Work quickly to complete next step.

9.13 Carefully remove Fiber Bundle Air Seal from fiber bundle. Approximately 3" - 4" of fiber bundle will be exposed. **See Fig. 7C.**

9.14 **Key Step.** Carefully bring Tube Coupling and 3" - 4" length of 8mm Clear Tube together and couple. Any fiber bundle slack may wave or snake inside 8mm Clear Tube as connection is made. **See Fig. 7D.**

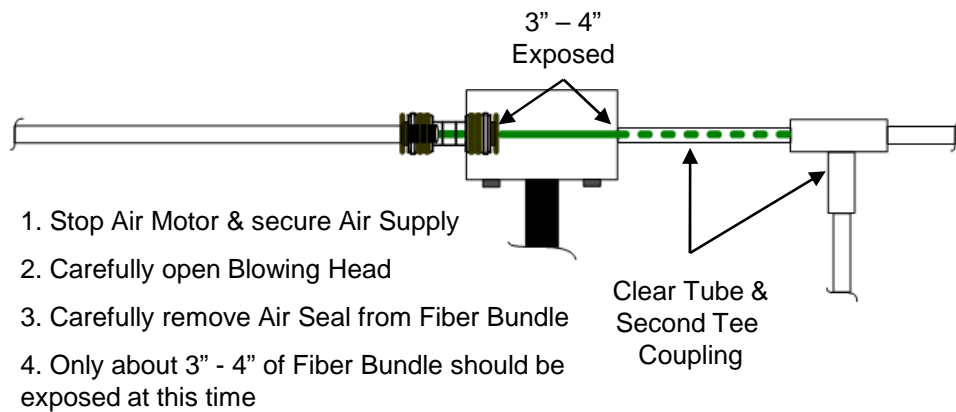

Figure 7C
 Open Blowing Head and Remove Air Seal

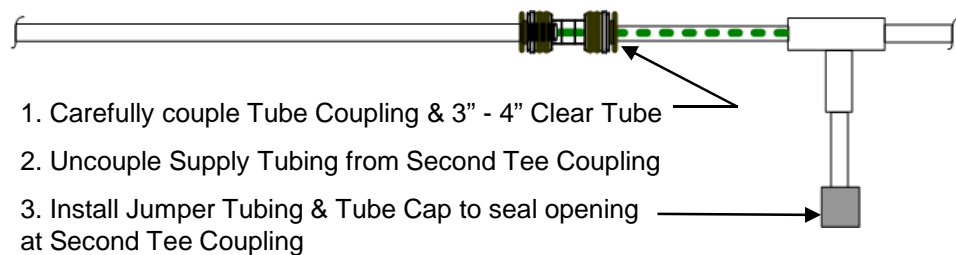

Figure 7D
 Carefully Couple Tube Coupling and Clear Tube

10.0 Completing Installation – At Entry Point FTU

10.1 At Point A FTU, allow Point A-to-Point B tube segment to de-pressurize / vent.

10.2 Leave fiber bundle installed in Blowing Head for additional protection.

10.3 Carefully manually pay off recommended 10' - 15' of fiber bundle length from reel for fiber termination purposes; more or less if required / desired. When enough length is available, cut fiber bundle from reel.

10.4 When tube span has de-pressurized, open Blowing Head and carefully remove Fiber Bundle Air Seal from around fiber bundle.

10.5 Carefully uncouple Supply Tubing from Branch Leg of Second Tee Coupling.

10.6 Carefully uncouple Second Tee Coupling and 8mm Clear Tube from tube span.

10.7 Carefully slide Second Tee Coupling and 8mm Clear Tube off cut end of fiber bundle and retain.

10.8 Coil and organize fiber bundle and protect it from accidental damage by storing inside FTU.

10.9 Carefully install a Fiber Bushing around fiber bundle and seat it in open end of tube to seal opening.

10.10 Secure loose end of fiber bundle to reel.

Remove fiber bundle reel from Payoff Stand and install reel's protective cover (Clamshell).

11.0 Completing Installation – At Point B TDU

11.1 At Point B TDU, allow Point B-to-Point C tube segment to fully de-pressurize / vent.

11.2 Carefully uncouple Supply Tubing from Branch Leg of Second Tee Coupling.

11.3 Push-fit a short length of tubing into Branch Leg of Second Tee Coupling. Push-fit a Tube Cap onto end of short tubing to seal Second Tee Coupling. **Refer to Fig. 7D.**

11.4 Carefully coil all jumper tubing and store inside Point B TDU. **See Fig. 8.**

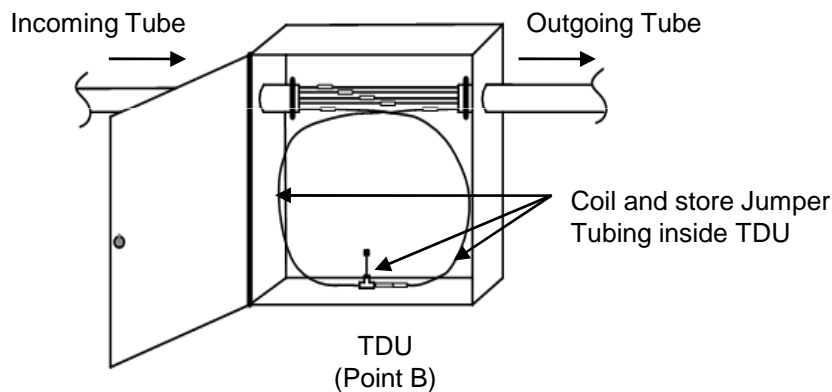

Figure 8
Store Jumper Tubing inside TDU

12.0 Completing Installation – At Exit Point FTU

12.1 At Point C FTU, allow Point B-to-Point C tube segment to de-pressurize / vent.

12.2 Carefully install a Fiber Bushing around fiber bundle and seat it in open end of tube to seal opening.

12.3 Remove and retain reusable Fiber Bundle Blowing Tip.

Note: It is recommended to leave Blowing Tip installed on fiber bundle and cut off first 2" - 3" of fiber bundle. This technique will help prevent the small Blowing Tip from being misplaced.

12.4 Coil and organize fiber bundle and protect it from accidental damage by storing inside FTU.

12.5 This completes the Tandem Blowing Procedure.

TABLE I
STANDARD FIBER BUNDLE BLOWING DISTANCES
USING ONE (1) BLOWING HEAD

2-, 4-, & 6-FIBER BUNDLES (2mm OD)	APPROX. BLOWING DISTANCE
All OSP tube cables	1500 meters or 5000 feet
TRX (Riser) tube cables	1000 meters or 3300 feet
TGX (General Purpose) tube cables	600 meters or 1950 feet
TPX (Plenum) tube cables	600 meters or 1950 feet
TP2 (Plenum) tube cables	600 meters or 1950 feet
NA4 (LS / ZH) tube cables	600 meters or 1950 feet

12-, 18-, & 24-FIBER BUNDLES (3mm OD)	APPROX. BLOWING DISTANCE
All OSP tube cables	1200 meters or 4000 feet
TRX (Riser) tube cables	1000 meters or 3300 feet
TGX (General Purpose) tube cables	300 meters or 1000 feet
TPX (Plenum) tube cables (N/A for 24-fiber bundles)	300 meters or 1000 feet
TP2 (Plenum) tube cables (N/A for 24-fiber bundles)	300 meters or 1000 feet
NA4 (LS / ZH) tube cables	300 meters or 1000 feet

Notes:

1. All distances given are approximate values
2. Several factors heavily influence actual blowing distances:
 - The location, number, and severity of bends in a tube cable run
 - The fiber bundle size installed (2mm OD or 3mm OD)
 - The tube cable type or types being blown through
3. Since 24-fiber Bundles contain four (4) nylon Sub Units and a Central Member, they are stiffer than and not as flexible as 12- and 18 Fiber Bundles. Consequently, 24-fiber bundle blowing distances may be slightly less than the approximate distances noted above if installed in tube cable routes with numerous tight bends.